

CANDIDATE
NAME

| |
|--|
| |
|--|

CENTRE
NUMBER

| | | | | |
|--|--|--|--|--|
| | | | | |
|--|--|--|--|--|

CANDIDATE
NUMBER

| | | | |
|--|--|--|--|
| | | | |
|--|--|--|--|

ENGLISH AS A SECOND LANGUAGE

1110/03

Paper 3 Listening

April 2018

approximately 45 minutes

Candidates answer on the Question Paper.

No Additional Materials are required.

READ THESE INSTRUCTIONS FIRST

Write your Centre number, candidate number and name on all the work you hand in.

While you are listening, write your answers on the question paper.

Write in dark blue or black pen.

Do not use staples, paper clips, highlighters, glue or correction fluid.

DO **NOT** WRITE IN ANY BARCODES.

Answer **all** questions.

You should pay attention to punctuation, spelling and handwriting.

At the end of the examination, fasten all your work securely together.

The number of marks is given in brackets [] at the end of each question or part.

The total number of marks for this paper is 30.

INFORMATION FOR CANDIDATES

There are six parts to the test.

You will hear each part twice.

For each part of the test there will be time for you to look through the questions and time for you to check your answers.

This document consists of **9** printed pages and **3** blank pages.



Part 1

Questions 1 – 5

For each question, there are three pictures and a short recording. Choose the correct picture and circle the letter **A**, **B** or **C** below it.

Example: Why did Jason visit Ally?

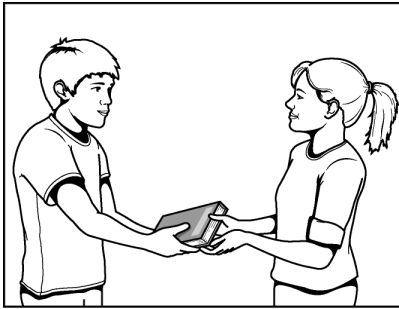

A

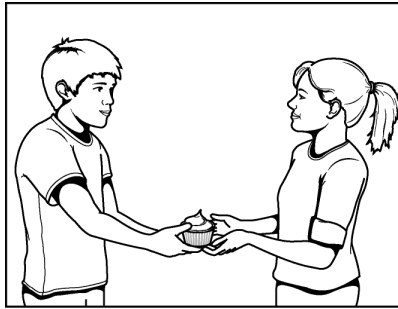

B

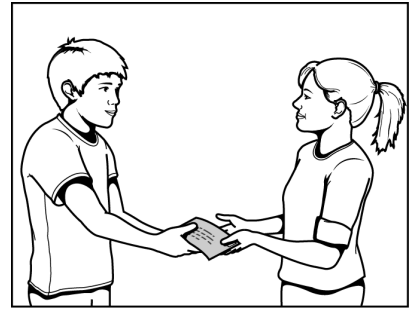

C

1 Which sport will the girl do today?

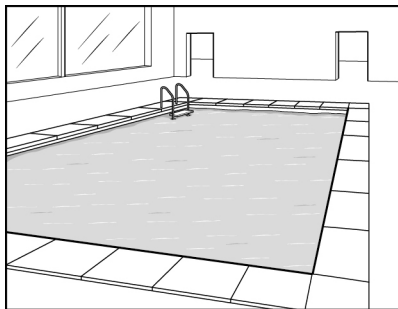

A

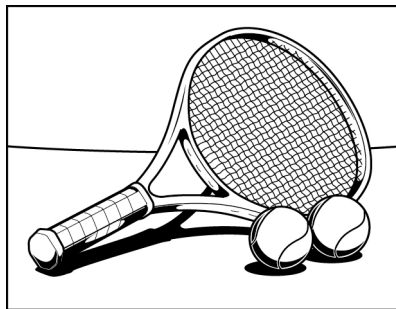

B

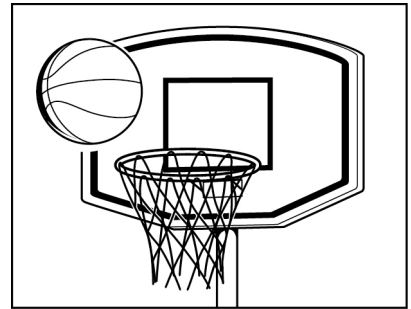

C

[1]

2 Where did the girl go on holiday this summer?

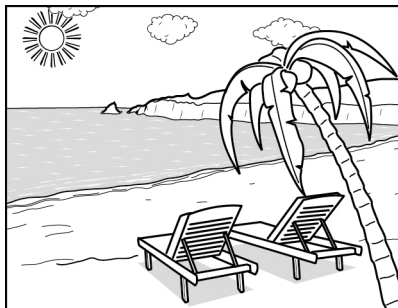

A



B

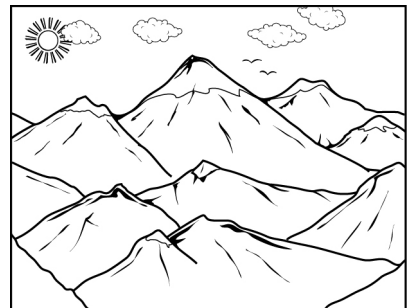

C

[1]

3 Which fruit do the people buy in the market?

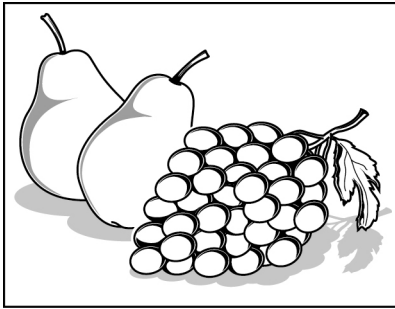

A

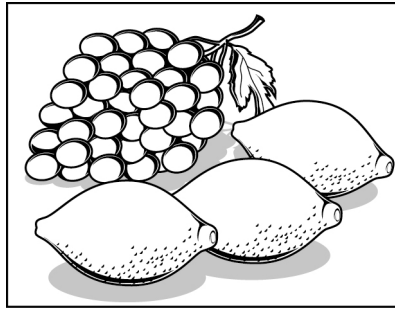

B

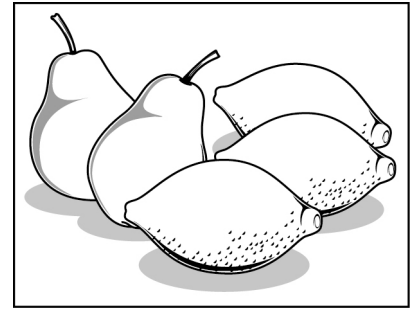

C

[1]

4 When did Paul's father's plane arrive?

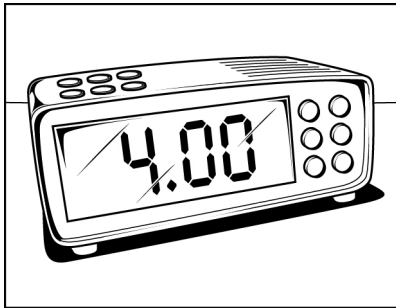

A

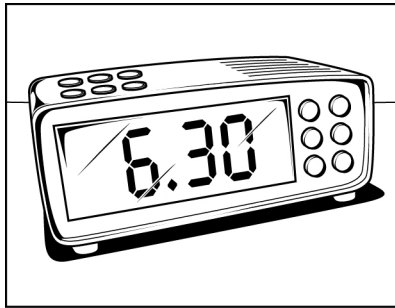

B

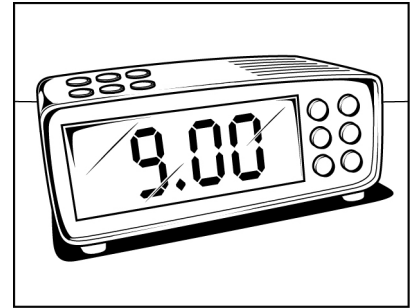

C

[1]

5 Which is the boy's maths teacher?

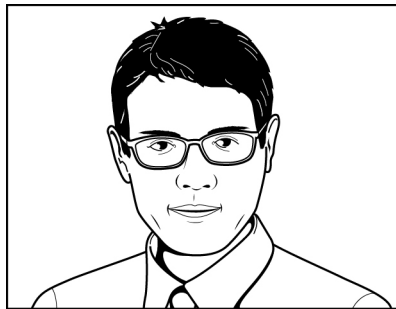

A



B



C

[1]

Part 2

Questions 6 – 10

For each question, there are three pictures and a short recording. Choose the correct picture and circle the letter **A**, **B** or **C** below it.

6 Which activity is Sara going to learn to do?



A



B



C

[1]

7 Which documentary programme is on tonight?



A

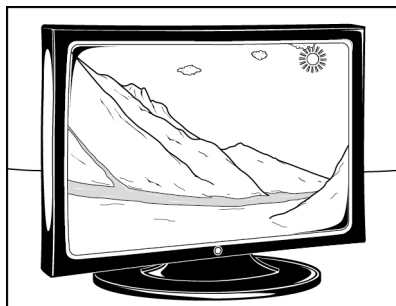

B



C

[1]

8 What is the boy collecting now?



A



B



C

[1]

9 Which job is the woman giving a talk about?



A

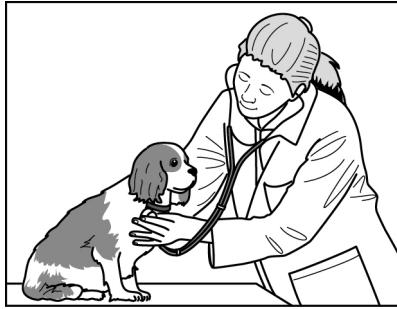

B



C

[1]

10 What was broken while the boy and his father were moving house?

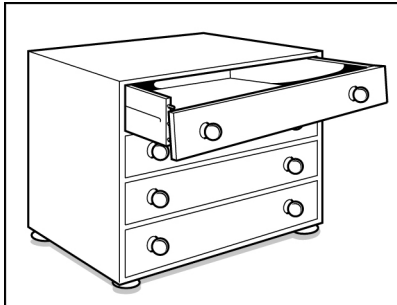

A



B

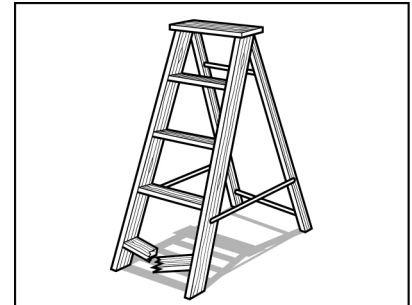

C

[1]

Part 3

Questions 11 – 15

You will hear people talking in five different situations.
For each question, circle the correct answer **A**, **B** or **C**.

11 You hear a boy talking about an art exhibition.

What did the boy dislike about the exhibition?

- A The place was too crowded.
- B The art was uninteresting.
- C The staff were annoying.

[1]

12 You overhear a girl leaving a voicemail message.

What does she want her friend to do?

- A go to the cinema with her
- B try a new ice cream shop in town
- C watch her brother play in a football match

[1]

13 You hear a dancer being interviewed on the radio.

What does he say about his working life?

- A He wishes he didn't have to work so hard.
- B He enjoys attending regular dance classes.
- C He feels lucky he can learn so much from others.

[1]

14 You hear a sports teacher talking to some students about a course.

What does she say is essential?

- A checking the latest information online
- B attending all the organised events
- C getting the right equipment

[1]

15 You hear part of a boy's presentation to his class about a trip abroad with his family.

What does he say about the trip?

- A Staying in campsites made him feel anxious.
- B Travelling by car made him feel bored.
- C Sightseeing made him feel tired.

[1]

Part 4

Questions 16 – 20

You will hear an interview with a woman called Yvonne about her job as a forest worker in a national park in Canada.

For each question, circle the correct answer **A**, **B** or **C**.

- 16** Yvonne decided to become a forest worker because
- A** she met someone who worked in a park.
 - B** she spent a lot of time in nature in her childhood.
 - C** she had learnt about the job in school.
- [1]
- 17** Which parts of the park is Yvonne working in at the moment?
- A** the lakes and rivers
 - B** the mountains
 - C** the campsites
- [1]
- 18** What does Yvonne like least about her job?
- A** dealing with difficult visitors
 - B** working near dangerous animals
 - C** spending so much time in an office
- [1]
- 19** Which season of the year does Yvonne enjoy the most?
- A** summer
 - B** autumn
 - C** winter
- [1]
- 20** What project is Yvonne working on now?
- A** making a historical display about the park
 - B** recording her day for a documentary
 - C** taking photographs of plants and flowers
- [1]

Part 5

Questions 21 – 25

You will hear a teacher giving students information about a class trip to a chocolate factory. For each question, fill in the missing information in the numbered space.

School Trip to Chocolate Factory

Tour of factory takes: **(21)** hours

On Arrival

- collect maps
- start worksheets
- meet tour guide: **(22)** Annie

Tour

- listen to talk about history of chocolate
- watch film: '**(23)** to Bar' about chocolate production
- meet professional chocolate makers

After tour

- visit shop
- free gift for every student: **(24)** of class

Lunch

- bottle of juice
- **(25)**
- an apple

[Total: 5 marks]

Part 6

Questions 26 – 30

You will hear an interview with a young man called Toby Daniels, who is a judoka, a student of the sport of judo.

For each question, circle the correct answer **A**, **B** or **C**.

26 What does Toby say about the first time he went to a judo club?

- A He loved the sport immediately.
- B He knew how difficult the sport was.
- C He was looking for a new sport to learn.



[1]

27 What does Toby say about the judo club he now belongs to?

- A It received a lot of publicity recently.
- B It is attracting many new members.
- C It has some of the best facilities available.

[1]

28 How has learning judo helped Toby in his daily life?

- A It has improved his concentration.
- B It has taught him to be more patient.
- C It has increased his self-confidence.

[1]

29 What does Toby say about performing at a judo competition in Scotland?

- A He felt more nervous than usual.
- B He was surprised by the size of the crowd.
- C He knew he had a good chance of winning.

[1]

30 What does Toby say about his judo coach?

- A He doesn't talk much.
- B He has lots of experience.
- C He never gets angry.

[1]

Permission to reproduce items where third-party owned material protected by copyright is included has been sought and cleared where possible. Every reasonable effort has been made by the publisher (UCLES) to trace copyright holders, but if any items requiring clearance have unwittingly been included, the publisher will be pleased to make amends at the earliest possible opportunity.

Cambridge International Examinations is part of the Cambridge Assessment Group. Cambridge Assessment is the brand name of University of Cambridge Local Examinations Syndicate (UCLES), which is itself a department of the University of Cambridge.